



Downstream Equipment Technical Data



Intelligent Air Technology

Model	Conn. Size*	Flow Rate† @ 7 bar g (102 psi g)		Dimensions mm					Weight Kg	Replacement Element Kit No.				
		m³/min	cfm	A	B	C	D	E		Grade A	Grade B/E	Grade C	Grade D	No.
CF 0005 (grade)	G¼	0.54	19	76	34.5	133	-	70	0.5	CE 0005 A	CE 0005 B	CE 0005 C	CE 0005 D	1
CF 0010 (grade)	G⅜	1.02	36	89	42	158	-	95	1.0	CE 0010 A	CE 0010 B	CE 0010 C	CE 0010 D	1
CF 0018 (grade)	G½	1.8	64	89	42	194	-	130	1.1	CE 0018 A	CE 0018 B	CE 0018 C	CE 0018 D	1
CF 0036 (grade)	G¾	3.6	127	120	58	251	-	172	2.4	CE 0036 A	CE 0036 B	CE 0036 C	CE 0036 D	1
CF 0048 (grade)	G1	4.8	170	120	58	351	-	272	2.9	CE 0087 A	CE 0087 B	CE 0087 C	CE 0087 D	1
CF 0072 (grade)	G1¼	7.2	254	120	58	351	-	272	2.9	CE 0087 A	CE 0087 B	CE 0087 C	CE 0087 D	1
CF 0087 (grade)	G1½	8.7	307	120	58	351	-	272	2.9	CE 0087 A	CE 0087 B	CE 0087 C	CE 0087 D	1
CF 0120 (grade)	G1½	12.0	424	160	66.5	511	-	320	9.1	CE 0132 A	CE 0132 B	CE 0132 C	CE 0132 D	1
CF 0132 (grade)	G2	13.2	466	160	66.5	511	-	320	9.1	CE 0132 A	CE 0132 B	CE 0132 C	CE 0132 D	1
CF 0198 (grade)	G2	19.8	699	160	66.5	816	-	625	12.9	CE 0198 A	CE 0198 B	CE 0198 C	CE 0198 D	1
CF 0240 (grade)	G2½	24.0	848	202	79	602	-	400	12.1	CE 0258 A	CE 0258 B	CE 0258 C	CE 0258 D	1
CF 0258 (grade)	G3	25.8	911	202	79	602	-	400	11.9	CE 0258 A	CE 0258 B	CE 0258 C	CE 0258 D	1
CF 0372 (grade)	G3	37.2	1314	202	79	844	-	625	20.9	CE 0372 A	CE 0372 B	CE 0372 C	CE 0372 D	1
CF 0600 (grade)	G4	60.0	2119	420	82	1095	-	570	44.5	CE 0198 A	CE 0198 B	CE 0198 C	CE 0198 D	3
CF 0120 (grade) F	DN 40	12.0	424	304	115	624	335	350	29	CE 0132 A	CE 0132 B	CE 0132 C	CE 0132 D	1
CF 0198 (grade) F	DN 50	19.8	699	304	120	934	335	650	37	CE 0198 A	CE 0198 B	CE 0198 C	CE 0198 D	1
CF 0372 (grade) F	DN 80	37.2	1314	390	177	1077	335	650	64	CE 0372 A	CE 0372 B	CE 0372 C	CE 0372 D	1
CF 0600 (grade) F	DN 100	60.0	2119	450	201	1140	335	650	95	CE 0198 A	CE 0198 B	CE 0198 C	CE 0198 D	3
CF 0780 (grade) F	DN 100	78.0	2755	500	230	1220	335	650	135	CE 0198 A	CE 0198 B	CE 0198 C	CE 0198 D	4
CF 1170 (grade) F	DN 150	117.0	4132	580	273	1294	335	650	177	CE 0198 A	CE 0198 B	CE 0198 C	CE 0198 D	6
CF 1950 (grade) F	DN 200	195.0	6886	750	361	1519	335	650	368	CE 0198 A	CE 0198 B	CE 0198 C	CE 0198 D	10
CF 3120 (grade) F	DN 250	312.0	11018	740	410	1684	335	800	515	CE 0198 A	CE 0198 B	CE 0198 C	CE 0198 D	16
CF 4680 (grade) F	DN 300	468.0	16527	1000	485	1777	335	850	684	CE 0198 A	CE 0198 B	CE 0198 C	CE 0198 D	24
CF 0004 CD	G¼	0.36	13	76	133	133	70	70	1.0	CE 0005 C & CE 0004 D				1+1
CF 0008 CD	G⅜	0.78	27	89	158	158	95	95	1.2	CE 0010 C & CE 0008 D				1+1
CF 0015 CD	G½	1.5	53	89	194	194	95	130	1.4	CE 0018 C & CE 0015 D				1+1
CF 0024 CD	G¾	2.4	84	120	251	251	125	172	3.2	CE 0036 C & CE 0024 D				1+1
CF 0039 CD	G1	3.9	136	120	251	351	125	272	3.7	CE 0087 C & CE 0039 D				1+1
CF 0051 CD	G1¼	5.1	178	120	351	351	225	272	3.8	CE 0087 C & CE 0051 D				1+1

*Fabricated housings flanged to BS 4504 PN16 and designed to CEN 286 Part 1 (1991). Other pressure vessel standards available.

†For flowrates at other pressures, apply the correction factor shown:

Maximum operating pressure (0005 to 4680-F) with autodrain (232 psi g)	16 bar g	Line	bar g	1	4	6	7	8	9	10	11	12	13	14	16	20
Maximum operating pressure (0005 to 0600) without autodrain(290 psi g)	20 bar g	Pressure	psi g	15	29	87	102	116	131	145	160	174	189	203	232	290
Maximum recommended operating temperature (Grade A/B/C/E)	66°C (150°F)	Correction factors		0.38	0.76	0.93	1	1.07	1.13	1.20	1.25	1.31	1.36	1.41	1.51	1.70
Maximum recommended operating temperature (Grade D)	30°C (86°F)	Initial differential pressure		Grade A ~100m bar (1.5 psi) Grade B ~140m bar (2.0 psi) Grade C ~200m bar (3.0 psi) Grade CD (0004 TO 0051) ~300m bar (4.5 psi) Grade D (0005 TO 4680-F) ~70m bar (1.0 psi) Grade E ~70m bar (1.0 psi)												
Minimum recommended operating temperature	1.5°C (35°F)	Maximum recommended pressure differential for element change: (A, B, C and E filters only)		~340m bar (5 psi)												

Model No Description

CF 0372 A F

CF 0372 A F — Fabricated Housing

CF 0372 A F — Filter Grade (A, B, C, D, E)

CF 0372 A F — Model Designation

0005 - 0018

0036 - 0087

0120 - 0600

0120-F - 4680-F

0004 - 0051 CD

Accessories			
Model No:	Mounting	Fixing	
All Grades	Grade: CD Bracket Kit		kit
0005	0004	CFA-05	CFA-10
0010 - 0018	0008 - 0015	CFA-06	CFA-10
0036 - 0087	0024 - 0051	CFA-07	CFA-11
0120 - 0198	NA	CFA-08	CFA-12
0240 - 0372	NA	CFA-09	CFA-13

TX Models

Flow Range @ 7 bar g:	2.18m ³ /min (77 cfm) to 93.19m ³ /min (3293 cfm)	Maximum Operating Pressure:	A22TX-A140TX 16 bar g (232 psi g) A190TX-A930TX 10 bar g (145 psi g)
Pressure Dewpoint:	-40°C (-40°F) Nominal -25°C (-13°F) Optional -70°C (-100°F) Optional	Minimum Operating Pressure:	4 bar g (58 psi g)
		Maximum Inlet Temperature:	50°C (122°F)
Air Quality Class:	ISO 8573.1 Class 1.2.1. Nominal ISO 8573.1 Class 1.3.1. Optional ISO 8573.1 Class 1.1.1. Optional	Minimum Inlet Temperature:	5°C (41°F)
		Controls:	Electronic or Pneumatic
		Standard Electrical Supply:	230V/1Ph/50Hz - 60Hz

Model	Flow Rate @ 7 bar g (102 psi g)		Dimensions mm			Weight kg	Inlet Filter	Outlet Filter	Conn. Size	Weight Kg
	m ³ /min	cfm	A	B	C					
A22TX	2.18	77	565	1725	490	119	G9XPD	G9ZPHD	G3/4"	127
A28TX	2.83	100	595	1745	490	154	G9XPD	G9ZPHD	G3/4"	162
A38TX	3.82	135	634	1806	490	196	G11XPD	G11ZPHD	G1	206
A50TX	4.98	176	660	1845	490	227	G11XPD	G11ZPHD	G1	237
A60TX	6.08	215	820	1892	555	281	G12XPD	G12ZPHD	G1 1/2	292
A87TX	8.66	306	874	1891	540	371	G12XPD	G12ZPHD	G1 1/2	382
A120TX	11.66	412	905	2007	585	337	G13XPD	G13ZPHD	G1 1/2	350
A140TX	14.15	500	1015	2026	776	416	G14XPD	G14ZPHD	G2	436
A190TX	19.13	676	1060	2080	840	640	F17XPD	F17ZPHD	DN80	744
A250TX	24.96	882	1270	2120	900	765	F19XPD	F19ZPHD	DN80	923
A320TX	32.46	1147	1350	2160	990	955	F19XPD	F19ZPHD	DN80	1113
A390TX	39.11	1382	1530	2210	1040	1095	F20XPD	F20ZPHD	DN100	1307
A490TX	49.24	1740	1600	2255	1100	1285	F30XPD	F30ZPHD	DN100	1498
A630TX	63.22	2234	1875	2365	1200	1590	F30XPD	F30ZPHD	DN100	1802
A770TX	76.55	2705	1925	2657	1250	1950	F40XPD	F40ZPHD	DN150	2246
A930TX	93.19	3293	2150	2815	1565	2700	F60XPD	F60ZPHD	DN150	3116

*Referenced to 20 °C (68 °F) and 1 bar a (14.5 psi a)**Please specify connection size A22TX-A630TX CE Marked. A770-A930TX TUV or other approval.

Correct Dryer Selection

- Select your correction factor for minimum pressure (CFP) to inlet of dryer
(Allow for system pressure losses when determining minimum operating pressure).

Minimum Pressure to Inlet of Dryer	bar g	4	5	6	7	8	9	10	11	12	13	14	15	16
	psi g	58	73	87	102	116	131	145	160	174	189	203	218	232
Correction Factor (CFP)		0.63	0.75	0.88	1.0	1.08	1.26	1.36	1.5	1.62	1.71	1.79	1.97	2.14

- Select your correction factor for maximum temperature (CFT) to inlet of dryer.

Maximum Temperature to Inlet of Dryer	°C	25	35	40	45	50
	°F	77	95	104	113	122
Heatless ATX Dryers (CFT)		1.0	1.0	0.91	0.82	0.79

- Calculate dryer capacity required following the equation below.
Inlet flow requirement = Dryer capacity requirements CFP x CFT.

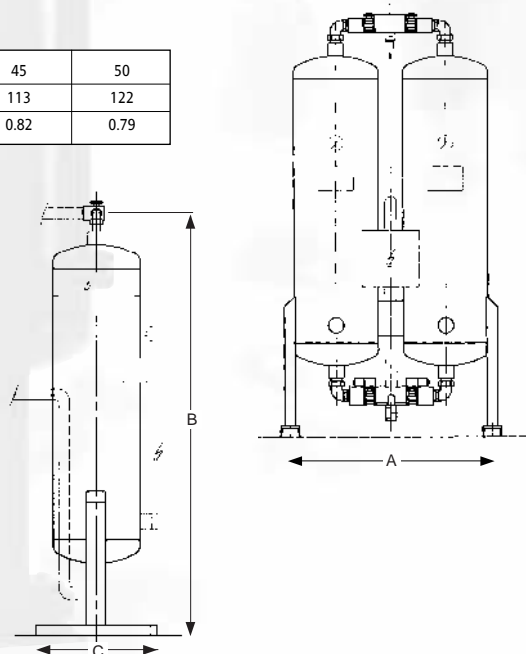



A Series Dryers

TV Models (Twin Tower Vacuum Purge)

Pressure Dewpoint:	-40°C (-40°F) Nominal	Maximum Operating Pressure:	10 bar g (145 psi g) Standard
	-25°C (-13°F) Optional		16 bar g (232 psi g) Optional
	-70°C (-100°F) Optional		4 bar g (73 psi g)
Air Quality Class:	ISO 8573.1 Class 1.2.1. Nominal	Maximum Inlet Temperature:	40°C (122°F)
	ISO 8573.1 Class 1.3.1. Optional	Minimum Inlet Temperature:	2°C (36°F)
	ISO 8573.1 Class 1.1.1. Optional	Controls:	Microprocessor or PLC
		Standard Electrical Supply:	400V/3Ph/50Hz

Model	Flow Rate @ 7 bar g		Dimensions mm			Inlet Filter	Outlet Filter	Air Connection	Weight kg	Average Power kW/h @ Dewpoint	
	m ³ /min	cfm	A	B	C					-25°C	-40°C
A70TV	7	247	1215	1955	992	G12XPD	G12ZPHD	DN40	460	3.1	3.4
A85TV	8.5	300	1215	2204	992	G13XPD	G13ZPHD	DN40	560	3.8	4.1
A107TV	10.7	377	1305	2248	1085	G13XPD	G13ZPHD	DN40	640	5.2	5.5
A142TV	14.2	500	1360	2271	1120	G14XPD	G14ZPHD	DN50	770	6.7	7.2
A197TV	19.7	695	1560	2664	1265	F17XPD	F17ZPHD	DN50	940	10.9	11.8
A250TV	25	883	1610	2680	1270	F19XPD	F19ZPHD	DN80	1200	12.8	13.0
A330TV	33	1165	1700	2730	1582	F19XPD	F19ZPHD	DN80	1580	16.3	17.5
A392TV	39.2	1383	2020	2845	1447	F20XPD	F20ZPHD	DN100	1880	18.1	19.5
A488TV	48.8	1725	2080	2870	1580	F30XPD	F30ZPHD	DN100	2350	22.5	24.2
A592TV	59.2	2089	2170	2940	1740	F30XPD	F30ZPHD	DN100	2850	27.9	29.3
A683TV	68.3	2413	2450	3190	1780	F30XPD	F30ZPHD	DN100	3300	32.5	34.2
A790TV	79	2790	2550	3210	2108	F40XPD	F40ZPHD	DN150	3800	38.9	40.2
A875TV	87.5	3090	2550	3226	1952	F40XPD	F40ZPHD	DN150	4200	44.8	45.2
A1035TV	103.5	3655	2600	3500	1910	F60XPD	F60ZPHD	DN150	4950	52.3	53.2
A1183TV	118.3	4179	2650	3521	1936	F60XPD	F60ZPHD	DN150	5700	56.3	57.0
A1333TV	133.3	4709	3209	3584	2176	F60XPD	F60ZPHD	DN150	6400	67.2	67.8
A1533TV	153.3	5415	3150	3804	2299	F80XPD	F80ZPHD	DN200	7400	75.6	76.8
A1800TV	180	6357	3250	3666	2353	F80XPD	F80ZPHD	DN200	8700	85.3	87.9
A2050TV	205	7240	3500	3853	2514	F100XPD	F100ZPHD	DN200	11500	98.9	105.0
A2417TV	241.7	8534	3600	3893	2566	F120XPD	F120ZPHD	DN250	13500	111.4	119.9

*Referenced to 20°C (68°F) and 1 bar a (14.5 psi a)

Correct Dryer Selection

- Select your correction factor for minimum pressure to inlet of dryer
(Allow for system pressure losses when determining minimum operating pressure).

Inlet Pressure	bar g	4	5	6	7	8	9	10
Inlet Temperature	30°C	0.69	0.80	0.90	1.02	1.06	1.17	1.29
	35°C	0.44	0.62	0.80	1.00	1.05	1.16	1.28
	40°C	0.28	0.42	0.59	0.70	0.79	0.88	0.96

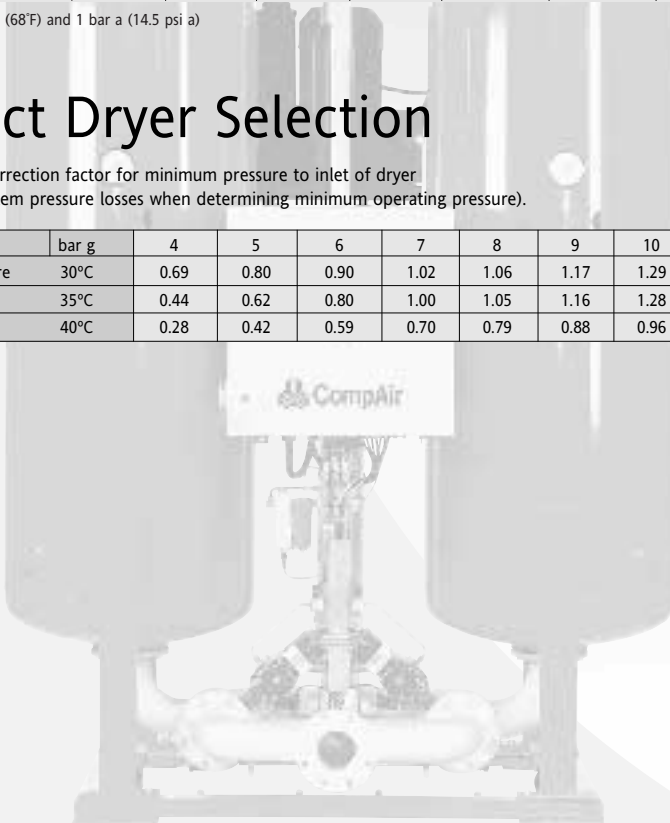
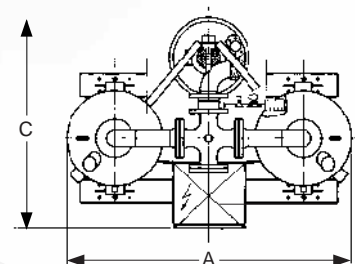
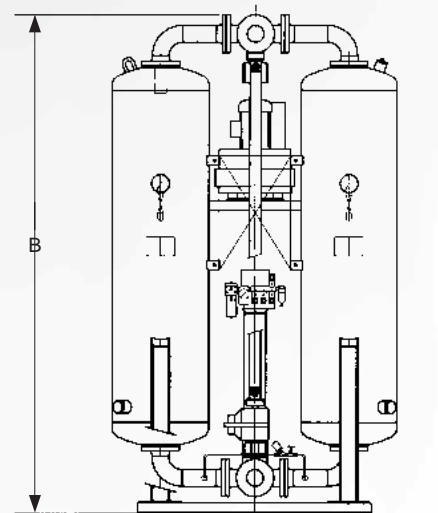

X & R Models (Heatless and Heat Regenerative)

Flow Range:	4.53m ³ /min (160 cfm) and upwards	Pipe Connections:	G2 to G2½
Pressure Dewpoint:	-40°C (-40°F) Nominal -70°C (-100°F) Optional (if -70°C pdp option required, contact CompAir)	Minimum Inlet Temperature:	5°C (41°F)
Minimum Working Pressure:	4 bar g (58 psi g)	Maximum Inlet Temperature:	50°C (122°F)
Maximum Working Pressure:	10.5 bar g (152 psi g)	Note: All CompAir dryers are supplied electrically operated as standard. Fully pneumatic versions are available on request (except R heat regenerative models).	

Inlet/Outlet Filtration (per dryer bank)

Models	Inlet Filter(s)	Outlet Filter
A45X - A110X	CF0132C	CF0132E
A40R - A80R	CF0132C	CF0132ETS
A140X - A900X	CF0240C	CF0240E
A120R - A790R	CF0240C	CF0240ETS

Voltages

Heatless:	220 - 240V/1ph/50Hz 110 - 115V/1ph/60Hz
Heat Regenerative:	380 - 415/3ph/50Hz 415/3ph/60Hz + Neutral
Other voltages and frequencies are available on request	

Electrical Specifications

(R heat regenerative models operating at 7 bar g and 35°C inlet temperature)

Model	Full load Amps	Power Consumption kW H Average
A40R	7.2	1.1
A80R	14.4	2.2
A120R	21.6	3.3
A160R	28.8	4.4
A190R	36.0	5.5

X Models (Heatless)

Model																			
		A45X	A70X	A90X	A110X	A140X	A160X	A180X	A230X	A270X	A320X	A360X	A450X	A540X	A680X	A720X	A900X		
Capacity at stated air inlet temperature	m ³ /min	up to 35°C	4.53	6.79	9.06	11.32	13.58	15.85	18.11	22.64	27.17	31.70	36.22	45.28	54.34	67.92	72.45	90.56	
		up to 45°C	3.98	5.98	7.97	9.96	11.95	13.95	15.94	19.92	23.91	27.89	31.88	39.85	47.82	59.77	63.75	79.69	
	cfm	up to 35°C	160	240	320	400	480	560	640	800	960	1119	1279	1599	1919	2399	2559	3198	
		up to 45°C	141	211	281	352	422	493	563	703	844	985	1126	1407	1689	2111	2251	2814	
Dewpoint	°C	-40																	
Air Connections	G	2	2	2	2	2½	2½	2½	2½	2½	2½	2½	2½	2½	2½	2½	2½	2½	
Dimensions	mm	width	240						740						1240		1740		
		height	1630																
		depth	692	798	905	1011	1118	1224	1311	1544	1118	1224	1311	1544	1311	1544	1311	1544	
Weight	kg	135	180	220	250	295	345	400	520	590	690	800	1040	1200	1560	1600	2080		
Minimum working pressure	bar	4																	
Maximum working pressure	bar	10.5																	
Max air inlet temperature	°C	50																	

R Models (Heat Regenerative)

Model														
		A40R	A80R	A120R	A160R	A190R	A240R	A320R	A390R	A480R	A590R	A630R	A790R	
Capacity at stated air inlet temperature	m ³ /min	up to 35°C	3.96	7.92	11.89	15.85	19.81	23.77	31.70	39.62	47.54	59.43	63.39	79.24
		up to 45°C	2.69	5.39	8.08	10.78	13.47	16.16	21.55	26.94	32.33	40.41	43.11	53.88
	cfm	up to 35°C	140	280	420	560	700	839	1119	1399	1679	2099	2239	2798
		up to 45°C	95	190	285	381	476	571	761	951	1142	1427	1903	
Dewpoint	°C	-40												
Nominal power absorbed	kW	1.1	2.2	3.3	4.4	5.5	6.6	8.8	11	13.2	16.2	17.6	22	
Air Connections	G	2	2	2½	2½	2½	2½	2½	2½	2½	2½	2½	2½	
Dimensions	mm	width	321				821				1321		1821	
		height	1630											
		depth	717	947	1177	1407	1637	1177	1407	1637	1407	1637	1407	1637
Weight	kg	150	245	325	440	565	650	880	1130	1320	1695	1760	2260	
Minimum working pressure	bar	4												
Maximum working pressure	bar	10.5												
Max air inlet temperature	°C	50												

Maximum Temperature to Inlet of Dryer	°C	25	35	40	45	50
	°F	77	95	104	113	122
X Model	CFT	1.0	1.0	0.97	0.88	0.73
R Model	CFT	1.1	1.0	0.76	0.58	0.45

Pressure Correction Table

Minimum Pressure to Inlet of Dryer	bar g	4	5	6	7	8	9	10
	psi g	58	73	87	102	116	131	145
Correction Factor (CFP)		0.63	0.75	0.88	1.0	1.13	1.25	1.38

S Models Heatless

Flow Range:	0.08m ³ /min (3 cfm) to 4.98m ³ /min (176 cfm)	Pipe Connections:	G ¹ / ₄ to G ³ / ₄
Pressure Dewpoint:	-40°C (-40°F) Nominal -70°C (-100°F) Optional (if -70°C pdp option required, contact CompAir)	Minimum Inlet Temperature:	5°C (41°F)
Minimum Working Pressure:	4 bar g (58 psi g)	Maximum Inlet Temperature:	50°C (122°F)
Maximum Working Pressure:	10.5 bar g (152 psi g)	Note: S Models are supplied electrically operated as standard. Fully pneumatic versions are available on request	
Voltages: Heatless: 220 - 240V/1ph/50Hz 110 - 115V/1ph/60Hz Other voltages and frequencies are available on request			

All dryers conform to ISO 8573.1 Air Quality Class (Dirt/Water/Oil) 1.1.1 and 1.2.1

Model		A1X	A2X	A4X	A7X	A9X	A12X	A15X	A18X	A25X	A30X	A37X	A50X	
Capacity at stated air inlet temperature	m ³ /min	up to 35°C	0.08	0.17	0.37	0.68	0.91	1.19	1.50	1.84	2.49	3.00	3.68	4.98
		up to 45°C	0.07	0.15	0.32	0.60	0.80	1.05	1.32	1.62	2.19	2.64	3.24	4.38
	cfm	up to 35°C	3.0	6.0	13.0	24	32	42	53	65	88	106	130	176
		up to 45°C	2.6	5.3	11.4	21	28	37	47	57	77	93	114	155
Dewpoint	°C	-40												
Air Connections	G	1/4	1/4	1/4	1/2	1/2	1/2	1/2	3/4	3/4	3/4	3/4	3/4	
Minimum working pressure	bar	4												
Maximum working pressure	bar	10.5												
Max air inlet temperature	°C	50												
Inlet Filter		CF0005 C			CF0018 C			CF0036 C		CF0037 C		CF0072 C		
Outlet Filter		CF0005 E			CF0018 E			CF0036 E		CF0037 E		CF0072 E		
Fixing Kit (1 per filter)		CFA10			CFA10			CFA11		CFA11		CFA11		

Dryers supplied complete with Inlet and Outlet Filter and Fixing Kits.

IMPORTANT NOTE:
Size the dryer against the minimum dryer inlet pressure or, if not known, 1 bar below the compressor minimum working pressure.

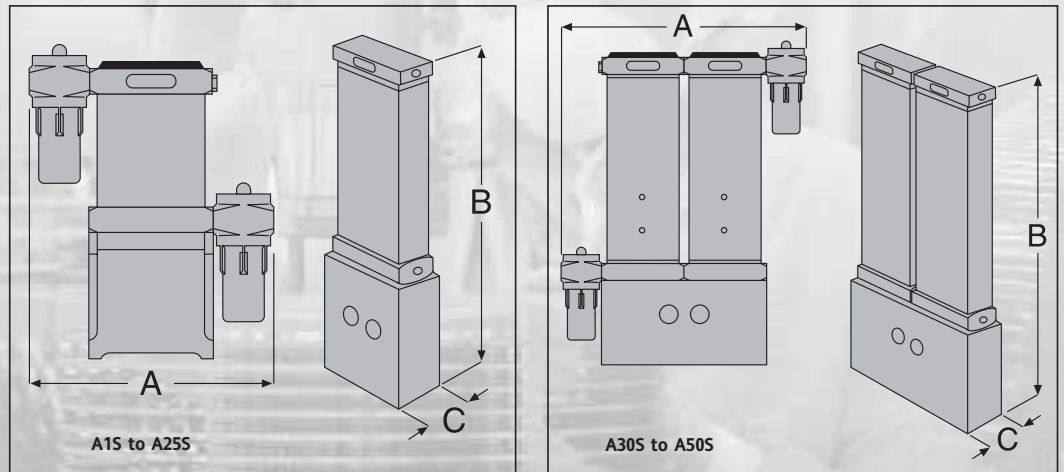

Model		A1S	A2S	A4S	A7S	A9S	A12S	A15S	A18S	A25S	A30S	A37S	A50S	
Dimensions	mm	Width (A)	305			426			500		760			
		Height (B)	370	465	705	690	856	1021	1186	1515	1763	1400	1566	1814
		Depth (C)	92			150			200					
Weight	kg	5	7	9	25	30	36	41	52	60	90	100	120	

Pressure Correction Table

Minimum Pressure to Inlet of Dryer	bar g	4	5	6	7	8	9	10
	psi g	58	73	87	102	116	131	145
Correction Factor (CFP)		0.63	0.75	0.88	1.0	1.13	1.25	1.38

F Series - Refrigeration Dryers

Model		F4H	F6H	F9H	F12H	F18H	F24H	F30H	F40H	F50H	F60H	F70H	F80H
Capacity at stated air inlet temperature	m ³ /min	0.4	0.6	0.9	1.2	1.8	2.4	3.0	4.0	5.0	6.0	7.0	8.0
	cfm	14.1	21.2	31.8	42.4	63.6	84.8	105.9	141	177	212	247	283
Dewpoint	°C	3											
Nominal power absorbed	kW	0.14	0.17	0.20	0.30	0.44	0.59	0.73	0.58	0.96	0.95	0.98	1.23
Air Connections	BSP-F	3/8	3/8	1/2	1/2	3/4	3/4	3/4	1 1/2	1 1/2	1 1/2	1 1/2	1 1/2
Dimensions	width	197		282		352		615					
	height	455		530		605		791					
	depth	450		600		700		552					
Weight	kg	18	20	32	33	46	55	58	65	66	68	70	73
Refrigerant		R134a						R407c					
Max air inlet temperature	°C	60											

Model		F110H	F140H	F180H	F220H	F270H	F370H	F450H	F600H	F770H	F900H	F1100H	
Capacity at stated air inlet temperature	m ³ /min	11.0	14.0	18.0	22.0	27.0	37.0	45.0	60.0	77.0	90.0	110.0	
	cfm	388	494	636	777	953	1307	1589	2119	2719	3178	3885	
Dewpoint	°C	3											
Nominal power absorbed	kW	1.21	1.49	1.49	2.11	2.72	3.19	4.38	5.63	8.57	7.72	9.93	
Air Connections	BSP-F	2	2	2	DN80	DN80	DN80	DN100	DN100	DN150	DN150	DN150	
Dimensions	width	920				1010							
	height	1015				1500							
	depth	672				1310				1810			
Weight	kg	140	144	150	400	420	450	470	550	580	590	660	
Refrigerant		R407c											
Max air inlet temperature	°C	60											

Working Pressure	bar g	3	4	5	6	7	8	9	10	11	12	13	14	15	16
Correction Factor	F4H-F30H	0.73	-	0.90	-	1.00	-	1.07	-	1.12	-	1.15	-	1.18	1.19
	F110H-F1100H	0.74	0.84	0.90	0.96	1.00	1.04	1.06	1.09	1.11	1.13	-	-	-	-

Ambient Temperature	°C	25	30	35	40	45	50
Correction Factor	F4H-F30H	1.00	0.94	0.88	0.81	0.75	0.68
	F40H-F1100H	1.00	0.96	0.92	0.88	0.80	0.70

Dryer Inlet Temperature	°C	30	35	40	45	50	55	60
Correction Factor	F4H-F30H	1.22	1	0.83	0.69	0.58	0.49	0.46
	F40H-F1100	1.20	1	0.84	0.71	0.60	0.50	0.45

X Series - Water Separators

Maximum operating pressure	16 bar g (232 psi g)
Maximum recommended operating temperature	66°C (150°F)
Minimum recommended operating temperature	1.5°C (35°F)
Typical pressure differential at rated flow	20 -60m bar (0.3 - 0.9 psi)

Line	bar g	1	3	5	7	9	11	13	15	16
Pressure	psi g	15	44	73	100	131	160	189	218	232
Correction Factor		0.5	0.71	0.87	1.0	1.12	1.22	1.32	1.41	1.56

Model	Pipe Size	Flow Rates @7 bar g (102 psi g)		Dimensions mm				Weight Kg
		m ³ /min	cfm	A	B	C	D	
X24	G1/2	2.4	85	89	42	158	60	1.0
X36	G3/4	3.6	127	89	42	194	60	1.1
X45	G1	4.5	159	85	23	197	60	1.1
X90	G1 1/2	9.0	318	120	58	251	80	2.7
X210	G2	21	742	160	67	511	100	5.9
X420	G2 1/2	42	1470	202	77	605	100	12.9
X480	G3	48	1695	202	77	605	100	12.9
X600	G4	60	2100	312	83	767	250	41
X480F	DN80	48	1695	390	177	900	285	65
X600F	DN100	60	2100	450	201	939	340	94
X1080F	DN180	108	3780	580	273	1021	460	177
X1800F	DN200	180	6300	750	361	1156	640	368
X2880F	DN250	288	10080	740	410	1272	715	507
X4320F	DN300	432	15120	1000	485	1290	840	675

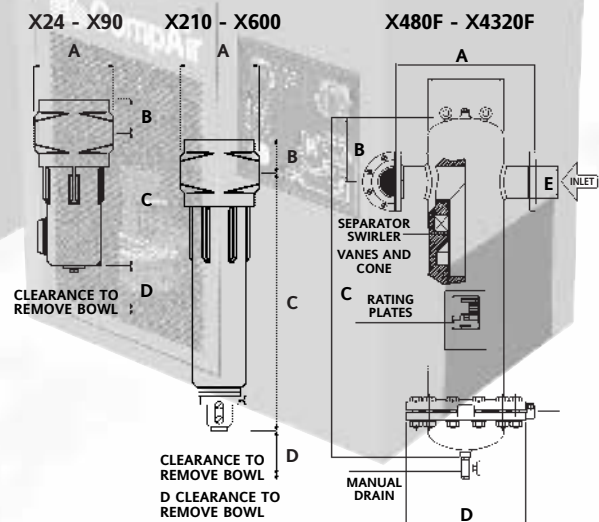

Intelligent Air Technology

Compressed air solutions for every application

Compressors

0.1 - 43m³/min
0.75 - 260kW

Lubricated

Rotary Vane
Single Stage Screw
Speed Regulated Screw
Piston
Portable

Oil-Free

Two Stage Screw
Water-Sealed Screw
Piston
Portable

Complete Accessories Programme

Filters and Dryers
Cooling Systems
Heat Recovery
Condensate Management
Air Receivers
Multi-Set Controllers
Lubricants

Value Added Services

Air Audit
Performance Reporting
Utility Air
Performance Contracting

Complete Service for Compressed Air Technology

Engineering of Complete Compressor Stations
Local Service Centres
Guaranteed Parts Availability



www.CompAir.com
Email sales@compair.com

CompAir policy is one of continuous improvement and we therefore reserve the right to alter specifications and prices without prior notice. All products are sold subject to the Company's conditions of sale.

Brochure re-order ref: 98700-435E
11/2003

